

A new section 12.14.100 of the Fife Municipal Code is adopted to read as follows:

12.14.100 Green Street or Arterial.

A Green Street or Arterial means a paved public or private right-of-way that either completely or partially manages stormwater on site through use of Low Impact Development Facilities that provide water quality benefits and infiltrates stormwater (if an infiltration facility); create attractive streetscapes that increase neighborhood livability by enhancing the pedestrian environment and introducing park-like elements into neighborhoods; serve as an urban greenway segment that connects neighborhoods, parks, recreation facilities, schools, main streets, and wildlife habitats; and meets broader community goals by providing pedestrian and where appropriate bicycle access. (Ord. XXXX, 2008).

A new section 12.20.025 of the Fife Municipal Code is adopted to read as follows:

12.20.025 Required public improvements – Green Streets.

All right of way improvements that change the drainage characteristics of the right-of-way shall incorporate Low Impact Development Facilities or Techniques into redevelopment or enhancement projects in the right of way as required by the current stormwater requirements including but not limited to an increase in impervious surfaces, increase in drainage volumes, and time-to-peak runoff. Streets designated as principal arterials and the North Levee Road, are exempt from this section. For improvements to existing streets, Low Impact Development shall be used to the maximum extent possible. For new streets, Green Streets standards shall be used per FMC 12.20.045, FMC 12.20.055, FMC 12.20.065, and FMC 12.20.075. (Ord. XXXX, 2008).

Fife Municipal Code section 12.20.030 shall be amended to read as follows:

12.20.030 Required public improvements – Alleys.

The pavement width of an alley must be at least 10 feet but may be required to be increased by the Community Development Director. For all commercial, industrial, office or multifamily projects, the applicant shall improve the alley opposite the subject property and extend it to the existing improved street, and may be required to improve an additional 30 feet past the property frontage to provide emergency turn-around. Additional paving may be required as determined by the Fire Marshall. Alleys shall be paved with a permeable pavement surfacing. For single-family projects, the applicant shall improve the alley abutting the subject property and extend it to the existing improved street. The Community Development Director shall determine the extent and nature of other improvements required in alleys on a case-by-case basis and shall determine when exemptions are appropriate. (Ord. 1027 § 3, 1990; Ord. XXXX, 2008).

Fife Municipal Code section 12.20.040 shall be amended to read as follows:

12.20.040 Single-Family Access Street.

The standards for a single-family access street are as set forth in Exhibit "A" which follows.

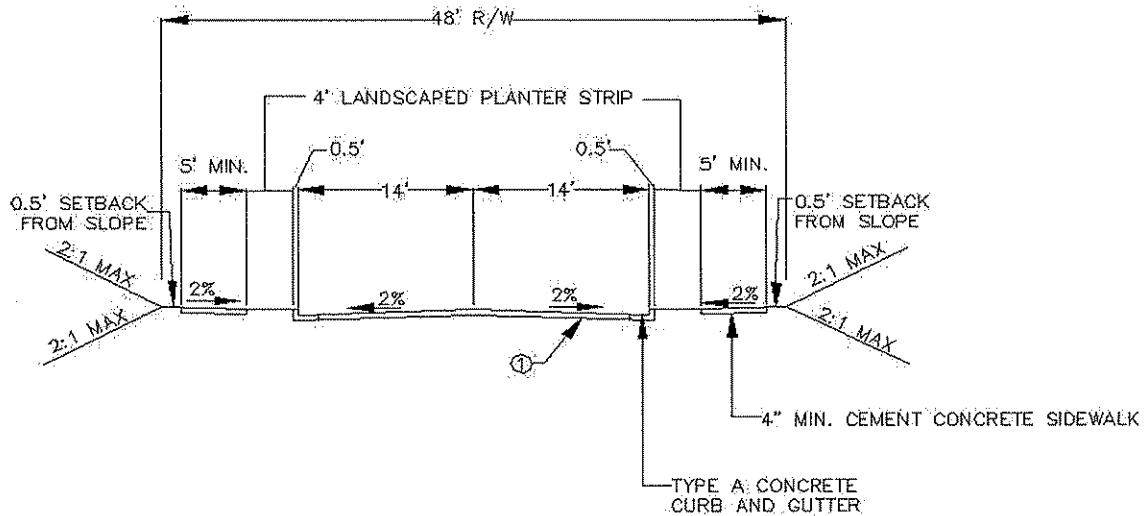

Notes:

1. The minimum allowable depth is two inches asphalt pavement HMA Class ½ inch PG64-22 overlying two inches crushed surfacing top course and 10 inches of the Aggregate for Gravel Base specification 9-03.10 of the 2008 WSDOT Standard Specifications. All thicknesses are compacted depths.
2. Minimum vertical slope: 0.5 percent.
3. Standards are minimum standards. Director of public works may require more than the minimum due to other adopted plans and regulations by the city or as field conditions warrant.
4. Cul-de-sac bulb shall have radius as determined by the fire marshall.
5. The director of public works may permit rolled Portland cement concrete curbs for special conditions, such as narrow single-family or duplex lots.

A new section 12.20.045 of the Fife Municipal Code is adopted to read as follows:

12.20.045 Single-Family Access Green Street.

The standards for a Single-Family Access Green Street are as set forth in Exhibit "A-1" which follows.

Exhibit A-1: Single-Family Access Green Street

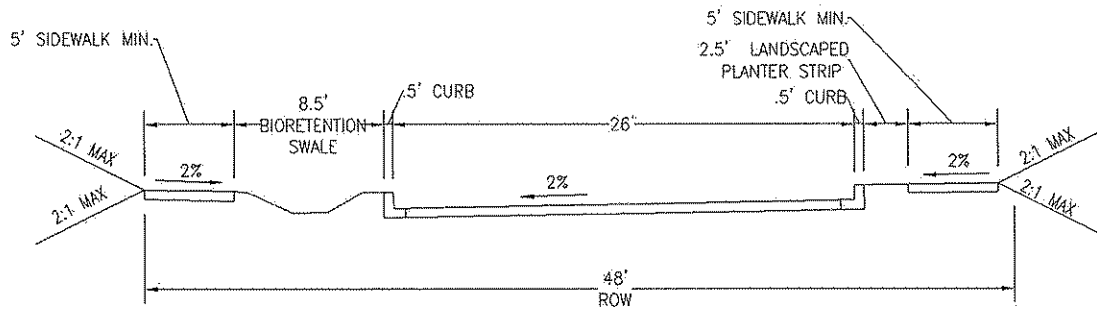

Notes:

1. The minimum allowable depth is two inches asphalt pavement HMA Class ½ inch PG64-22 overlying two inches crushed surfacing top course and 10 inches of the Aggregate for Gravel Base specification 9-03.10 of the 2008 WSDOT Standard Specifications. All thicknesses are compacted depths.
2. Minimum vertical slope: 0.5 percent.
3. Standards are minimum standards. Director of public works may require more than the minimum due to other adopted plans and regulations by the city or as field conditions warrant.
4. Cul-de-sac bulb shall have radius as determined by the Fire Marshall.
5. The director of public works may permit rolled Portland cement concrete curbs for special conditions, such as narrow single-family or duplex lots.
6. Sidewalks shall be constructed of a permeable pavement surfacing unless adjacent to a bioretention facility, or other drainage facility.
7. See bioretention swale definition in Title 21 FMC. Bioretention swales shall be engineered in accordance with the Stormwater Manual (see FMC 15.32).
8. Where feasible, curb extensions shall be installed per Section 21.30.030 FMC.

(Ord. 1595-06 § 2, 2006; Ord. 1027 § 4, 1990; Ord. XXXX, 2008).

Fife Municipal Code section 12.20.050 shall be amended to read as follows:

12.20.050 Commercial and Multifamily Access Street.

The standards for a neighborhood access street are as set forth in Exhibit “B” which follows.

Exhibit B: Commercial and Multifamily Access Street

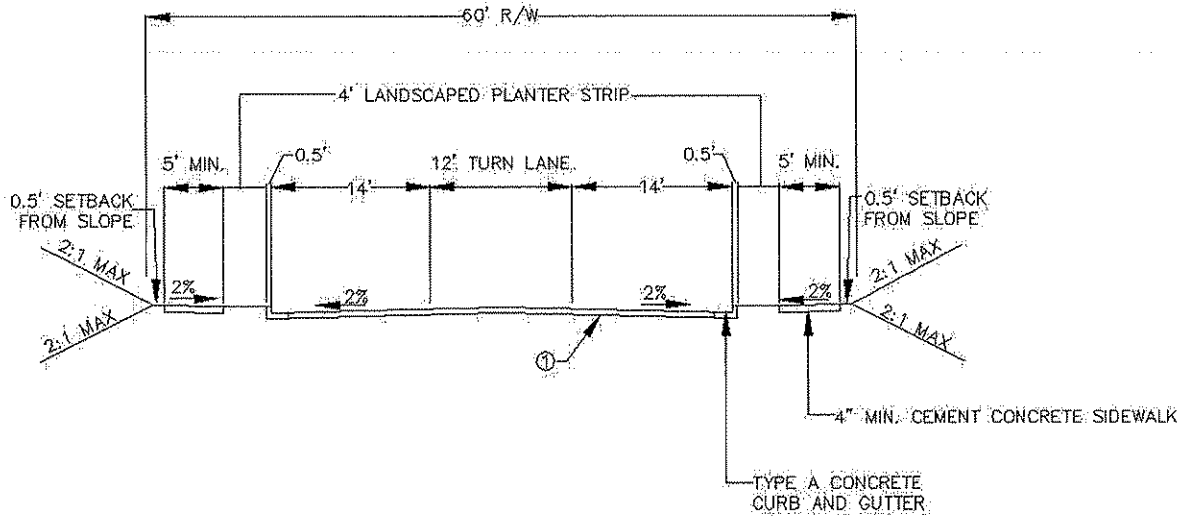

Notes:

1. The minimum allowable depth is four inches asphalt pavement HMA Class ½ inch PG64-22 overlying two inches crushed surfacing top course and 16 inches of the Aggregate for Gravel Base specification 9-03.10 of the 2008 WSDOT Standard Specifications. All thicknesses are compacted depths.
2. Minimum vertical slope: 0.5 percent.
3. Standards are minimum standards. Director of public works may require more than the minimum due to other adopted plans and regulations by the city or as field conditions warrant.

A new section 12.20.055 of the Fife Municipal Code is adopted to read as follows:

12.20.055 Commercial and Multifamily Access Green Street.

The standards for a Commercial and Multifamily Access Green Street are as set forth in Exhibit "B-1" which follows.

Exhibit B-1: Commercial and Multifamily Access Green Street

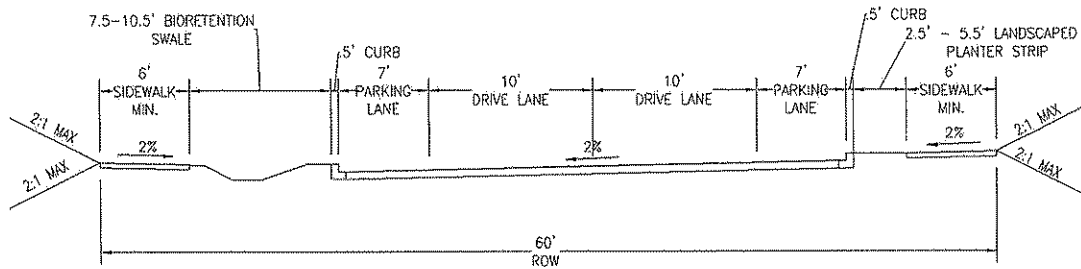

Notes:

1. The minimum allowable depth is two inches asphalt pavement HMA Class ½ inch PG64-22 overlying two inches crushed surfacing top course and 10 inches of the Aggregate for Gravel Base specification 9-03.10 of the 2008 WSDOT Standard Specifications. All thicknesses are compacted depths.
 2. Minimum vertical slope: 0.5 percent.
 3. Standards are minimum standards. Director of public works may require more than the minimum due to other adopted plans and regulations by the city or as field conditions warrant.
 4. Sidewalks shall be constructed of a permeable pavement surfacing unless adjacent to a bioretention facility, or other drainage facility.
 5. See bioretention swale definition in Title 21 FMC. Bioretention swales shall be engineered in accordance with the Stormwater Manual (see FMC 15.32).
 6. Where feasible, curb extensions shall be installed per Section 21.30.030 FMC.
- (Ord. 1595-06 § 3, 2006; Ord. 1027 § 5, 1990; Ord. XXXX, 2008).

Fife Municipal Code section 12.20.060 shall be amended to read as follows:

12.20.060 Collector street.

The standards for a neighborhood collector/collector arterial are as set forth in Exhibit “C” which follows.

Exhibit C: Collector Street

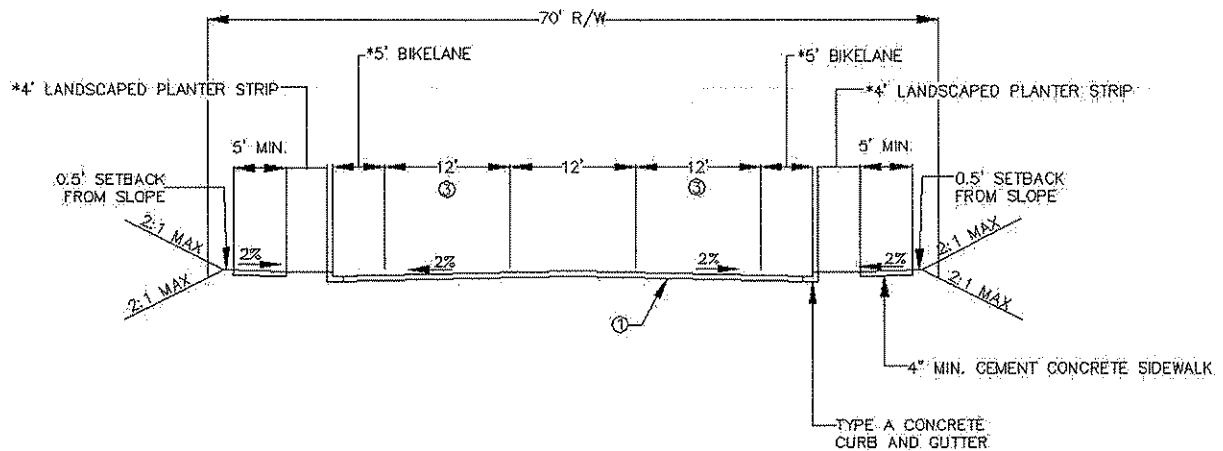

Notes:

1. The minimum allowable depth is four inches asphalt pavement HMA Class ½ inch PG64-22 overlying two inches crushed surfacing top course and 16 inches gravel base of Aggregate for Gravel Base specification 9-03.10 of the 2008 WSDOT Standard Specifications. All thicknesses are compacted depths.
2. Minimum vertical slope: 0.25 percent.
3. * Curb lane 14 feet wide where bike lane not required.
4. Standards are minimum standards. Director of public works may require more than the minimum due to other adopted plans and regulations by the city or as field conditions warrant.

A new section 12.20.065 of the Fife Municipal Code is adopted to read as follows:

12.20.065 Collector Green Street.

The standards for a Collector Green Street are as set forth in Exhibit “C-1” which follows.

Exhibit C-1: Collector Green Street

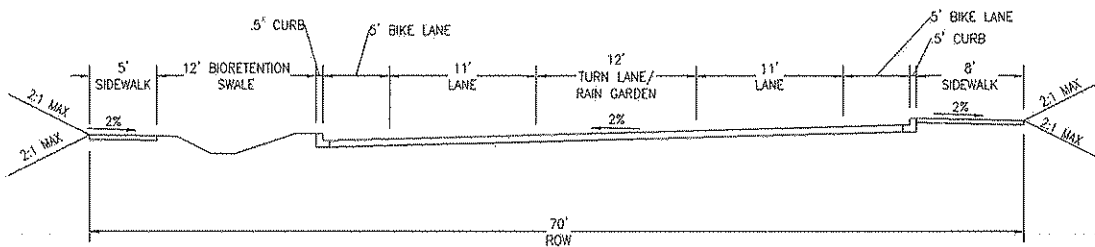

Notes:

1. The minimum allowable depth is two inches asphalt pavement HMA Class ½ inch PG64-22 overlying two inches crushed surfacing top course and 10 inches of the Aggregate for Gravel Base specification 9-03.10 of the 2008 WSDOT Standard Specifications. All thicknesses are compacted depths.
2. Minimum vertical slope: 0.25 percent.
3. Curb lane 14-feet wide where bike lane not required.
4. Standards are minimum standards. Director of public works may require more than the minimum due to other adopted plans and regulations by the city or as field conditions warrant.
5. Sidewalks shall be constructed of a permeable pavement surfacing unless adjacent to a bioretention facility, or other drainage facility.
6. See bioretention swale definition in Title 21 FMC. Bioretention swales shall be engineered in accordance with the Stormwater Manual (see FMC 15.32).
7. Where feasible, curb extensions shall be installed per Section 21.30.030 FMC.

(Ord. 1595-06 § 4, 2006; Ord. 1027 § 6, 1990; Ord. XXXX, 2008).

Fife Municipal Code section 12.20.070 shall be amended to read as follows:

12.20.070 Minor arterial.

The standards for a minor arterial are as set forth in Exhibit “D” and “D-1” which follows.

Exhibit D: Minor Arterial

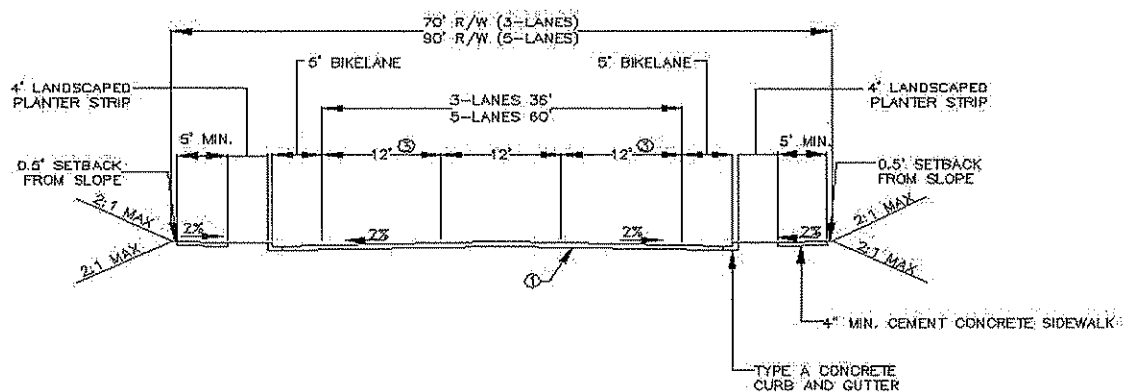
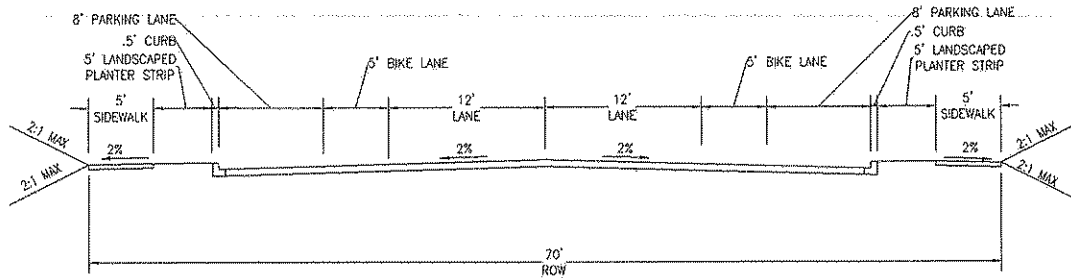

Exhibit D-1: Minor Arterial with Parking



Notes:

1. The minimum allowable depth is four inches asphalt pavement HMA Class ½ inch PG64-22 overlying two inches crushed surfacing top course and 16 inches gravel base Aggregate for Gravel Base specification 9-03.10 of the 2008 WSDOT Standard Specifications. All thicknesses are compacted depths.
2. Minimum vertical slope: 0.25 percent.
3. * Curb lane 14 feet wide where bike lane not required.
4. Standards are minimum standards. Director of public works may require more than the minimum due to other adopted plans and regulations by the city or as field conditions warrant.

A new section 12.20.075 of the Fife Municipal Code is adopted to read as follows:

12.20.075 Green Minor Arterial.

The standards for a green minor arterial are as set forth in Exhibit “D-2” which follows.

Exhibit D-2: Green Minor Arterial

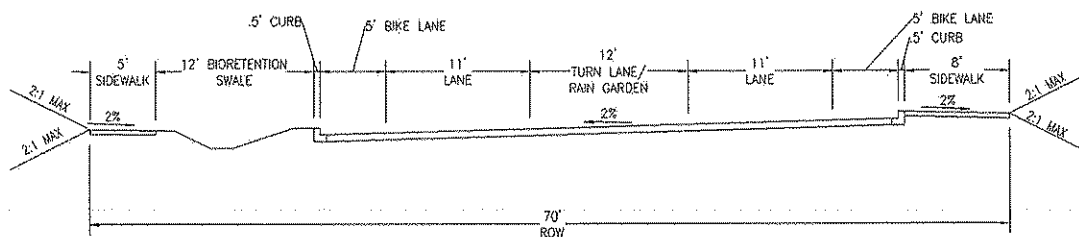

Notes:

1. The minimum allowable depth is two inches asphalt pavement HMA Class ½ inch PG64-22 overlying two inches crushed surfacing top course and 10 inches of the Aggregate for Gravel Base specification 9-03.10 of the 2008 WSDOT Standard Specifications. All thicknesses are compacted depths.
2. Minimum vertical slope: 0.25 percent.
3. * Curb lane 14 feet wide where bike lane not required.
4. Standards are minimum standards. Director of public works may require more than the minimum due to other adopted plans and regulations by the city or as field conditions warrant.
5. Sidewalks shall be constructed of a permeable pavement surfacing unless adjacent to a bioretention facility, or other drainage facility.
6. See bioretention swale definition in Title 21 FMC. Bioretention swales shall be engineered in accordance with the Stormwater Manual (see FMC 15.32).
7. Where feasible, curb extensions shall be installed per Section 21.30.030 FMC.

(Ord. 1595-06 § 5, 2006; Ord. 1027 § 7, 1990; Ord. XXXX, 2008).

Fife Municipal Code section 12.20.080 shall be amended to read as follows:

12.20.080 Principal Arterial.

The standards for a principal arterial are as set forth in Exhibit “E” which follows.

Exhibit E: Principal Arterial

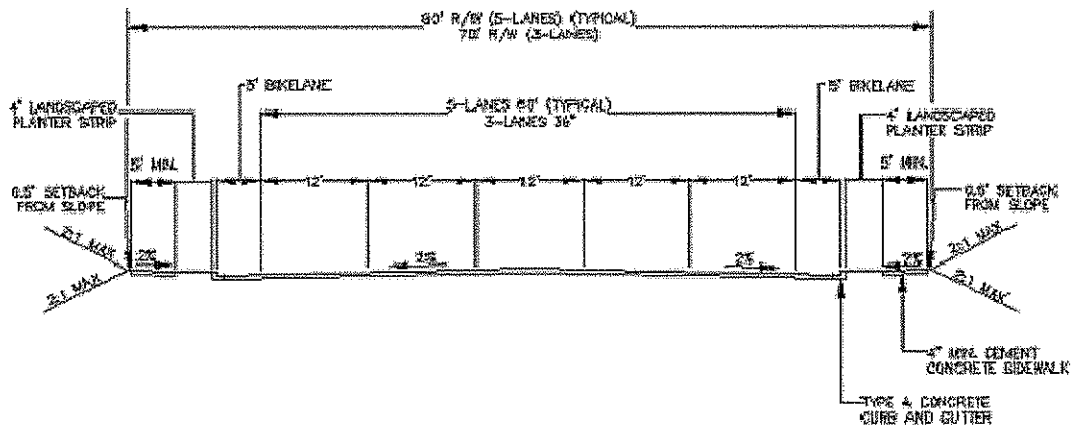

Notes:

1. The minimum allowable depth is two inches asphalt pavement HMA Class ½ inch PG64-22 overlying two inches crushed surfacing top course and 10 inches of the Aggregate for Gravel Base specification 9-03.10 of the 2008 WSDOT Standard Specifications. All thicknesses are compacted depths.
2. Minimum vertical slope: 0.25 percent.
3. Curb lane 14 feet wide where bike lane not required.
4. Center turn lane or one travel lane in each direction may be omitted in special circumstances.
5. Standards are minimum standards. Director of Public Works may require more than the minimum due to other adopted plans and regulations by the city or as field conditions warrant.
6. Sidewalks shall be constructed of a permeable pavement surfacing unless adjacent to a bioretention facility, or other drainage facility.
7. Where feasible, curb extensions shall be installed per Section 21.30.030 FMC.

(Ord. 1595-06 § 6, 2006; Ord. 1027 § 8, 1990; Ord. XXXX, 2008).

Fife Municipal Code section 12.20.085 shall be amended to read as follows:

12.20.085 Levee Road.

The standards for construction of North Levee Road East are shown on Exhibit “F” which follows.

Exhibit F: North Levee Road East

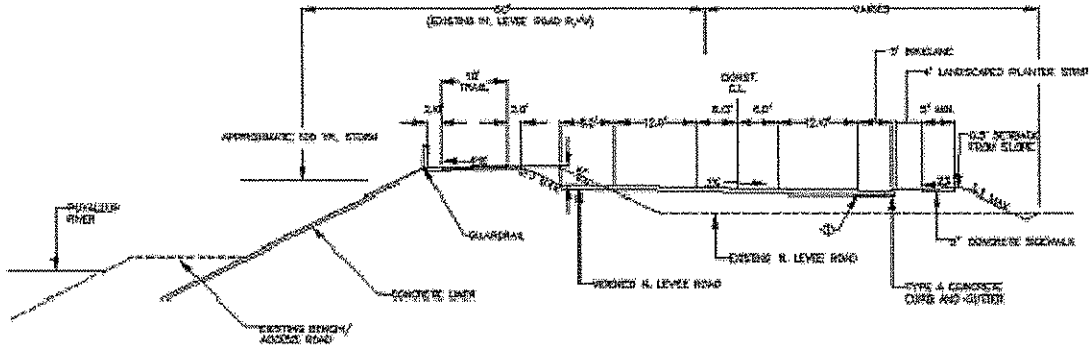

Notes:

1. The minimum allowable depth is two inches asphalt pavement HMA Class ½ inch PG64-22 overlying two inches crushed surfacing top course and 10 inches of the Aggregate for Gravel Base specification 9-03.10 of the 2008 WSDOT Standard Specifications. All thicknesses are compacted depths.
2. Minimum vertical slope: 0.25 percent.
3. Sidewalk/bikeway combinations or sidewalk location and width as required, four-inch depth.
4. Standards are minimum standards. Director of public works may require more than the minimum due to other adopted plans and regulations by the city or as field conditions warrant.

(Ord. 1595-06 § 7, 2006; Ord. XXXX, 2008).

Fife Municipal Code section 12.20.090 shall be amended to read as follows:

12.20.090 Additional Requirements.

E. Low Impact Development. See FMC Chapter 15.32.020. (Ord. XXXX, 2008).

F. Low Impact Development Facilities. See Title 21 FMC.

G. Low Impact Development Techniques. See Title 21 FMC.

Fife Municipal Code subsection 12.22.010(E and F) shall be amended to read as follows:

